

Stech- und Abstechwerkzeuge Grooving and Parting off Tools

4



Drehen
Turning

Fräswerkzeuge
Milling Tools

HDS-/VHM- Fräser
HDS-/ Solid Carbide
Endmills



Stech- und
Abstechwerkzeuge
Grooving and
Parting off Tools

Mini/ Micro
Schneidwerkzeuge
Mini/ Micro Tools



Gewinde-
werkzeuge
Threading Tools



Wendepplattenbohrer
VHM-Bohrer
Indexable Drills
Solid Carbide Drills

... Qualität schafft Vertrauen



Drehen
Turning

Fräswerkzeuge
Milling Tools







HDS-/VHM-Fräser
HDS-/ Solid Carbide
Endmills

Stech- und
Abstechwerkzeuge
Grooving and
Parting off Tools

Mini/ Micro
Schneidwerkzeuge
Mini/ Micro Tools

Gewinde-
werkzeuge
Threading Tools

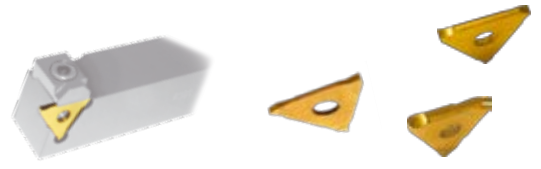
Wendeplattenbohrer
VHM-Bohrer
Indexable Drills
Solid Carbide Drills

		Seite Page
G.T.S. Stechdrehsystem G.T.S. Grooving Tooling System	260 262 270 272 290	 4.04
G.T.S. Stechdreh Einsätze G.T.S. Grooving Inserts	216 218 222 226 232	 4.10
Stechdrehwerkzeuge und Einsätze Grooving Tools and inserts	217	 4.11
Stechdrehwerkzeuge und Einsätze Grooving Tools and inserts	229	 4.16
Stechdrehwerkzeuge und Einsätze Grooving Tools and inserts	312	 4.20
Abstech-Werkzeuge Parting-off Tools	 4.28	
System-Auswahl Stechdrehwerkzeuge Choice of System Grooving Tools		4.32
Schnittdaten-Empfehlungen Cutting Data Recommendations		4.33
SDGN - Stechsystem Grooving System	 4.34	
Schneidstoff-Übersicht Description of Carbide Grades		4.36

Drehen
Turning

Fräswerkzeuge
Milling Tools

HDS-/VHM- Fräser
HDS-/Solid Carbide
Endmills

Stech- und
Abstechwerkzeuge
Grooving and
Parting off Tools

Mini/ Micro
Schneidwerkzeuge
Mini/ Micro Tools

Gewinde-
werkzeuge
Threading Tools

Wendepplattenbohrer
VHM-Bohrer
Indexable Drills
Solid Carbide Drills

R/L 260

Einstecken, Stechdrehen *Grooving, Groove Turning* System G.T.S.

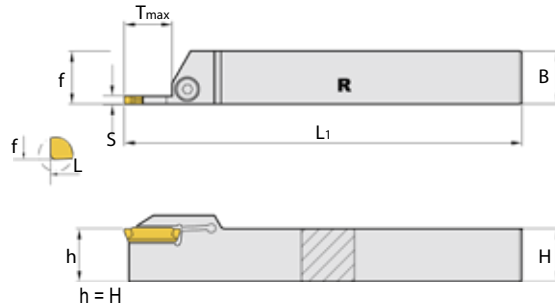
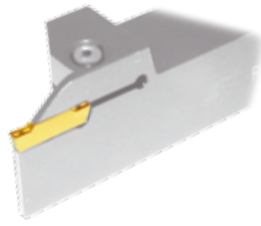

Drehen
Turning

Fräswerkzeuge
Milling Tools

HDS-/VHM-Fräser
HDS-/Solid Carbide
Endmills

Stech- und
Abstechwerkzeuge
Grooving and
Parting off Tools

Mini/Micro
Schneidwerkzeuge
Mini/Micro Tools

Gewinde-
werkzeuge
Threading Tools

Wendepplattenbohrer
VHM-Bohrer
Indexable Drills
Solid Carbide Drills

Bezeichnung Part Number	Lager Stock		Maße [mm] Dimensions				Seite / Page: 4.11 s [mm]	Ersatzteile <i>Spare Parts</i>							
	R	L	H=B	L ₁	f	T _{max}									
R/L 260. 1212. 015	●		12	80	12.3	12	216.0150... s=1,5 mm	32.15.115	48.12.606						
R/L 260. 1616. 015	○	○	16	100	16.3	14.5									
R/L 260. 2020. 015	○	○	20	125	20.3	14.5									
R/L 260. 2525. 015	○		25	150	25.4	14.5									
R/L 260. 1212. 02	●		12	100	12.3	12	216.0200... s=2,0 mm			32.15.115	48.12.606				
R/L 260. 1616. 02	●	●	16	100	16.3	14.5									
R/L 260. 2020. 02	●	●	20	125	20.3	14.5									
R/L 260. 2525. 02	●	○	25	150	25.4	14.5									
R/L 260. 1616. 025	●	●	16	100	16.3	14.5	218.0250... s=2,5 mm					32.15.114	48.11.602		
R/L 260. 2020. 025	●	●	20	125	20.3	14.5									
R/L 260. 2525. 025	○	○	25	150	25.4	14.5									
R/L 260. 1212. 03			12	100	12.3	12	222.0300... s=3,0 mm							32.15.114	48.11.602
R/L 260. 1616. 03	●	●	16	100	16.3	18									
R/L 260. 2020. 03	●	●	20	125	20.4	18									
R/L 260. 2525. 03	●	●	25	150	25.4	18									
R/L 260. 3232. 03	○	○	32	170	32.4	18	222.0400... s=4,0 mm	32.15.114	48.11.602						
R/L 260. 1616. 04			16	100	16.3	18									
R/L 260. 2020. 04	●	●	20	125	20.4	18									
R/L 260. 2525. 04	●	●	25	150	25.4	18									
R/L 260. 3232. 04	○	○	32	170	32.4	18	226.0500... s=5,0 mm			32.15.114	48.11.602				
R/L 260. 2020. 05	○	○	20	125	20.5	23									
R/L 260. 2525. 05	●	○	25	150	25.5	23									
R/L 260. 3232. 05	○	○	32	170	32.5	23	226.0600... s=6,0 mm					32.15.114	48.11.602		
R/L 260. 2020. 06	○		20	125	20.6	23									
R/L 260. 2525. 06	○	○	25	150	25.6	23									
R/L 260. 3232. 06	○	○	32	170	32.6	23									

Ausführung R oder L angeben / state R or L version

R/L 261/265

System G.T.S.

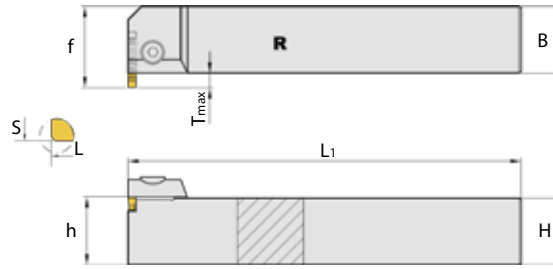
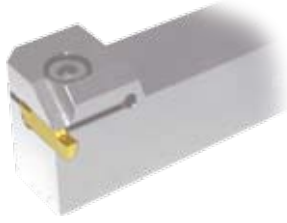

Drehen
Turning

Fräswerkzeuge
Milling Tools

HDS-/VHM-Fräser
HDS-/Solid Carbide
Endmills

Stech- und
Abstechwerkzeuge
Grooving and
Parting off Tools

Mini/ Micro
Schneidwerkzeuge
Mini/ Micro Tools

Gewinde-
werkzeuge
Threading Tools

Wendepplattenbohrer
VHM-Bohrer
Indexable Drills
Solid Carbide Drills

Bezeichnung Part Number	Lager Stock		Maße [mm] Dimensions				Seite / Page: 4.11 s [mm]	Ersatzteile Spare Parts	
	R	L	H=B	L ₁	f	T _{max}			
R/L 261. 2020. 015			20	125	23	3	216.0150... s=1,5 mm	32.15.114	48.11.602
R/L 261. 2525. 015			25	150	28	3			
R/L 261. 3232. 015			32	170	35	3			
R/L 261. 2020. 02			20	125	23.5	3.5	216.0200... s=2,0 mm		
R/L 261. 2525. 02			25	150	28.5	3.5			
R/L 261. 3232. 02			32	170	35.5	3.5			
R/L 261. 2020. 025			20	125	24	4	218.0250... s=2,5 mm		
R/L 261. 2525. 025			25	150	29	4			
R/L 261. 3232. 025			32	170	36	4			
R/L 261. 2020. 03			20	125	25.5	5	222.0300... s=3,0 mm		
R/L 261. 2525. 03			25	150	30.5	5			
R/L 261. 3232. 03			32	170	37.5	5			
R/L 261. 2020. 04			20	125	25.5	5	222.0400... s=4,0 mm		
R/L 261. 2525. 04			25	125	30.5	5			
R/L 261. 3232. 04			32	170	37.5	5			
R/L 261. 2020. 05			20	125	27	7	226.0500... s=5,0 mm		
R/L 261. 2525. 05			25	150	32	7			
R/L 261. 3232. 05			32	170	39	7			
R/L 261. 2020. 06			20	125	27	7	226.0600... s=6,0 mm		
R/L 261. 2525. 06			25	150	32	7			
R/L 261. 3232. 06			32	170	39	7			
R/L 261. 2525. 08			25	150	34	9	232.0800... s=8,0 mm		
R/L 261. 3232. 08			32	170	41	9			
R/L 265. 2525. 06			25	150	32	7	226.0600... s=6,0 mm		
R/L 265. 3232. 06			32	170	39	7			
R/L 265. 2525. 08			25	150	34	9	232.0800... s=8,0 mm		
R/L 265. 3232. 08			32	170	41	9			

Ausführung R oder L angeben / state R or L version

R/L 262/266

Eckenfreistechen, außen *Corner releasing, external*

System G.T.S.

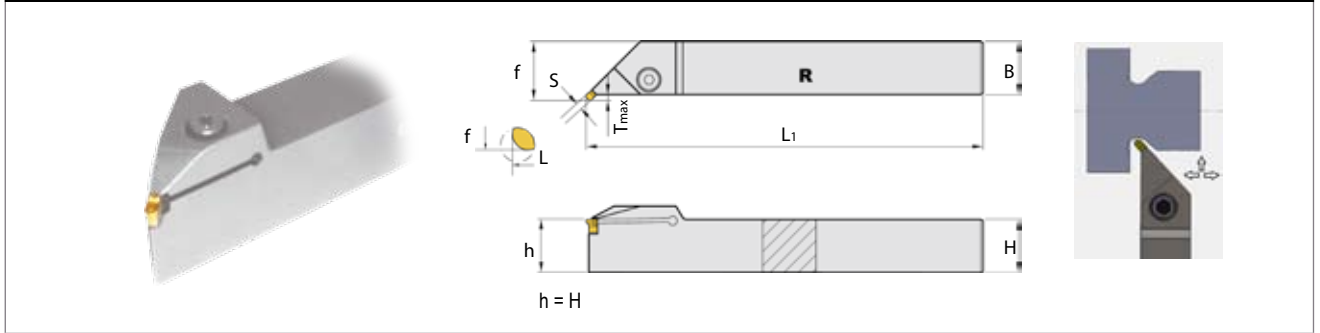

Drehen
Turning

Fräswerkzeuge
Milling Tools

HDS-/VHM-Fräser
HDS-/Solid Carbide
Endmills

Stech- und
Abstechwerkzeuge
Grooving and
Parting off Tools

Mini/Micro
Schneidwerkzeuge
Mini/Micro Tools

Gewinde-
werkzeuge
Threading Tools

Wendepplattenbohrer
VHM-Bohrer
Indexable Drills
Solid Carbide Drills

Bezeichnung Part Number	Lager Stock		Maße [mm] Dimensions				Seite / Page: 4.11 s [mm]	Ersatzteile Spare Parts	
	R	L	H=B	L ₁	f	T _{max}			
R/L 262. 2020. 03	○		20	125	23	3	222.0300... s=3mm	32.15.114	48.11.602
R/L 262. 2525. 03			25	150	28	3			
R/L 262. 3232. 03			32	170	35	3			
R/L 262. 2020. 04			20	125	23	3	222.0400... s=4mm		
R/L 262. 2525. 04	○		25	125	28	3			
R/L 262. 3232. 04			32	170	35	3			
R/L 262. 2020. 05			20	125	24	4	226.0500... s=5mm		
R/L 262. 2525. 05			25	150	29	4			
R/L 262. 3232. 05			32	170	36	4			
R/L 262. 2020. 06			20	125	24	4	226.0600... s=6,0 mm		
R/L 262. 2525. 06			25	150	29	4			
R/L 262. 3232. 06			32	170	36	4			
R/L 266. 2525. 06			25	150	29	4	226.0600... s=6,0 mm		
R/L 266. 3232 06			32	170	36	4			
R/L 266. 2525. 08			25	150	30	5	232.0800... s=8,0 mm		
R/L 266. 3232. 08			32	170	37	5			

Ausführung R oder L angeben / state R or L version

R/L 290

Axialstechen Face Grooving

System G.T.S.

Drehen
Turning

Fräswerkzeuge
Milling Tools

HDS-/VHM-Fräser
HDS-/Solid Carbide
Endmills

Stech- und
Abstechwerkzeuge
Grooving and
Parting off Tools

Mini/ Micro
Schneidwerkzeuge
Mini/ Micro Tools

Gewinde-
werkzeuge
Threading Tools

Wendepplattenbohrer
VHM-Bohrer
Indexable Drills
Solid Carbide Drills



Abb. zeigt rechtes Werkzeug

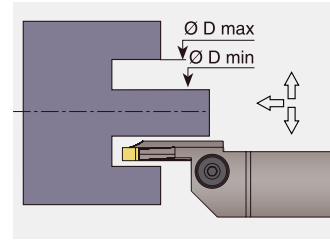
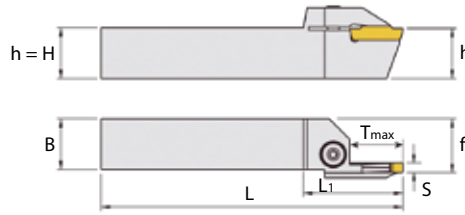

Bezeichnung Part Number	Lager Stock		Maße [mm] Dimensions						Seite / Page: 4.11 s [mm]	Ersatzteile Spare Parts	
	R	L	H=B	L	L ₁	f	T _{max}	Startdurchmesser Ø			
R/L290. 2525. 03-34/45	●	○	25	150	40	25	17	34-45	222.0300... s=3mm		
R/L290. 2525. 03-39/55	●	○	25	150	40	25	17	39-55			
R/L290. 2525. 03-50/60	●	○	25	150	40	25	17	50-60			
R/L290. 2525. 03-60/80	●	○	25	150	40	25	17	60-80			
R/L290. 2525. 03-80/110	●	○	25	150	40	25	17	80-110			
R/L290. 2525. 03-110/150	●	○	25	150	40	25	17	110-150			
R/L290. 2525. 04-50/60	○	○	25	150	45	25	20	50-60	222.0400... s=4mm	32.30.116	48.11.602
R/L290. 2525. 04-60/80	○	○	25	150	46	25	20	60-80			
R/L290. 2525. 04-80/110	○	○	25	150	46	25	20	80-110			
R/L290. 2525. 04-110/150	○	○	25	150	46	25	20	110-150			
R/L290. 2525. 04-140/600	○	○	25	150	49	25	25	140-600	226.0500... s=5mm		
R/L290. 2525. 05-50/80	○	○	25	150	45	25	20	50-80			
R/L290. 2525. 05-80/110	○	○	25	150	45	25	20	80-110			
R/L290. 2525. 05-110/150	○	○	25	150	45	25	20	110-150			
R/L290. 2525. 05-140/350	○	○	25	150	45	25	20	140-350			
R/L290. 2525. 05-350/500	○	○	25	150	45	25	20	350-500			
R/L290. 2525. 05-140/600	○	○	25	150	49	25	25	140-600			

Ausführung R oder L angeben / state R or L version

R/L 270/271 IK

Inneneinstechen mit Innenkühlung Grooving internal with through coolant

System G.T.S.

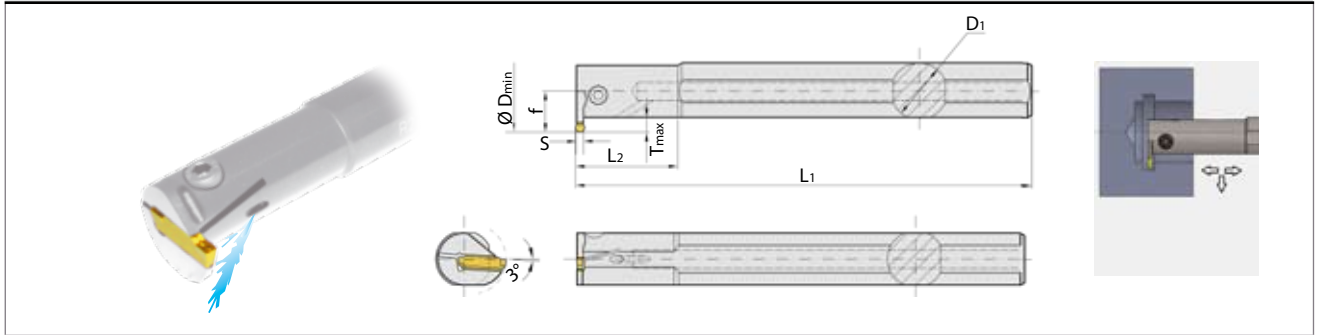

Drehen
Turning

Fräswerkzeuge
Milling Tools

HDS-/VHM-Fräser
HDS-/Solid Carbide
Endmills

Stech- und
Abstechwerkzeuge
Grooving and
Parting off Tools

Mini/Micro
Schneidwerkzeuge
Mini/Micro Tools

Gewinde-
werkzeuge
Threading Tools

Wendepplattenbohrer
VHM-Bohrer
Indexable Drills
Solid Carbide Drills

Bezeichnung Part Number	Lager Stock		Maße [mm] Dimensions						Seite / Page: 4.11 s [mm]	Ersatzteile Spare Parts	
	R	L	D _{min}	D ₁	L ₁	L ₂	T _{max}	f			
R/L 270. 0016. 015 -IK			20	16	125	35	4	11.3	216.0150... s=1,5 mm	32.45.123	48.12.603
R/L 270. 0020. 015 -IK			25	20	150	45	4	13.1		32.15.115	48.12.606
R/L 270. 0025. 015 -IK			29	25	200	45	4	16.2			
R/L 270. 0016. 02 -IK	●	●	20	16	135	35	5	12.4	216.0200... s=2,0 mm	32.45.123	48.12.603
R/L 270. 0020. 02 -IK	●	●	25	20	150	45	5	14.0		32.15.115	48.12.606
R/L 270. 0025. 02 -IK			29	25	200	45	5	17.2			
R/L 270. 0016. 025 -IK	●	○	21	16	125	35	6	13.3	218.0250... s=2,5 mm	32.45.123	48.12.603
R/L 270. 0020. 025 -IK			25	20	150	45	6	15.1			
R/L 270. 0025. 025 -IK			29	25	200	45	6	18.2			
R/L 270. 0020. 03 -IK	●	●	25	20	150	45	6	15.6	222.0300... s=3,0 mm		
R/L 270. 0025. 03 -IK	●	●	31	25	200	45	6	18.9			
R/L 270. 0032. 03 -IK	○	○	37	32	250	65	6	21.5			
R/L 270. 0020. 04 -IK	●	●	25	20	150	45	6	15.6	222.0400... s=4,0 mm		
R/L 270. 0025. 04 -IK	●	○	31	25	200	45	6	18.9			
R/L 270. 0032. 04 -IK	○	○	37	32	250	65	6	21.5			
R/L 270. 0025. 05 -IK			31	25	200	45	8	19.4	226.0500... s=5,0 mm	32.15.115	48.12.606
R/L 270. 0032. 05 -IK			37	32	250	65	8	21.5			
R/L 270. 0025. 06 -IK			31	25	200	45	8	19.4	226.0600... s=6,0 mm		
R/L 270. 0032. 06 -IK			37	32	250	65	8	21.5			
R/L 271. 0025. 06 -IK			31	25	200	45	8	19.4	226.0600... s=6,0 mm		
R/L 271. 0032. 06 -IK			37	32	250	65	8	21.5			
R/L 271. 0032. 08 -IK			37	32	250	65	10	23.4	232.0800... s=8,0 mm		
R/L 271. 0040. 08 -IK			45	40	300	70	10	27.2			

Ausführung R oder L angeben / state R or L version

R/L 272/273

Eckenfreistechen, innen *Corner releasing, internal* System G.T.S.

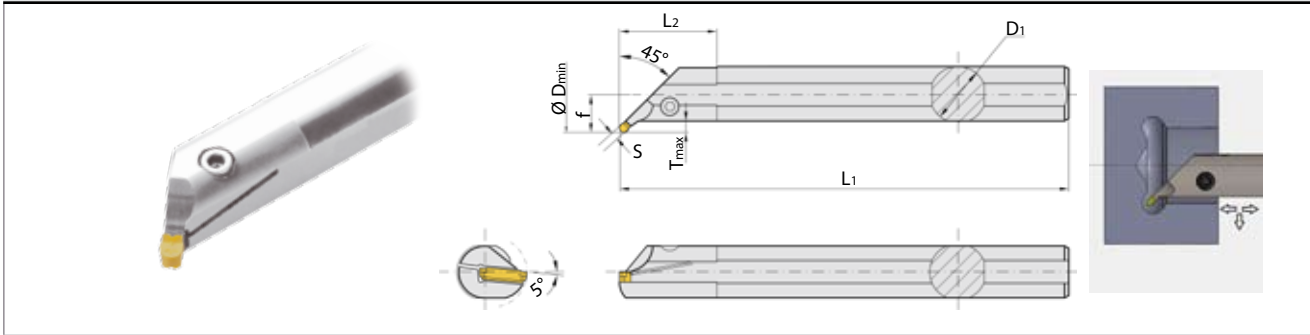

Bezeichnung Part Number	Lager Stock		Maße [mm] Dimensions						Seite / Page: 4.11 s [mm]	Ersatzteile <i>Spare Parts</i>	
	R	L	D _{min}	D ₁	L ₁	L ₂	T _{max}	f			
R/L 272. 0020. 03			35	20	150	45	3.5	13	222.0300... s=3,0 mm	32.15.115	48.12.606
R/L 272. 0025. 03			40	25	200	45	3.5	15.5			
R/L 272. 0032. 03			50	32	250	65	3.5	19			
R/L 272. 0020. 04			35	20	150	45	3.5	13	222.0400... s=4,0 mm		
R/L 272. 0025. 04			40	25	200	45	3.5	15.5			
R/L 272. 0032. 04			50	32	250	65	3.5	19			
R/L 272. 0025. 05			40	25	200	45	3.5	15.5	226.0500... s=5,0 mm		
R/L 272. 0032. 05			50	32	250	65	3.5	19			
R/L 272. 0025. 06			40	25	200	45	3.5	15.5	226.0600... s=6,0 mm		
R/L 272. 0032. 06			50	32	250	65	3.5	19			
R/L 273. 0025. 06			40	25	200	45	3.5	15.5	226.0600... s=6,0 mm		
R/L 273. 0032. 06			50	32	250	65	3.5	19			
R/L 273. 0025. 08			40	25	200	45	6.5	18.5	232.0800... s=8,0 mm		
R/L 273. 0032. 08			50	32	250	65	6.5	22			

Ausführung R oder L angeben / *state R or L version*

Drehen
Turning

Fräswerkzeuge
Milling Tools

HDS-/VHM-Fräser
HDS-/Solid Carbide
Endmills

Stech- und
Abstechwerkzeuge
Grooving and
Parting off Tools

Mini/ Micro
Schneidwerkzeuge
Mini/ Micro Tools

Gewinde-
werkzeuge
Threading Tools

Wendepplattenbohrer
VHM-Bohrer
Indexable Drills
Solid Carbide Drills

216/218/222/226

Einsätze zum Stechdrehen Inserts for Grooving and Turning

System G.T.S.

Drehen
Turning

Fräswerkzeuge
Milling Tools

HDS-/VHM-Fräser
HDS-/Solid Carbide
Endmills

Stech- und
Abstechwerkzeuge
Grooving and
Parting off Tools

Mini/Micro
Schneidwerkzeuge
Mini/Micro Tools

Gewinde-
werkzeuge
Threading Tools

Wendepplattenbohrer
VHM-Bohrer
Indexable Drills
Solid Carbide Drills

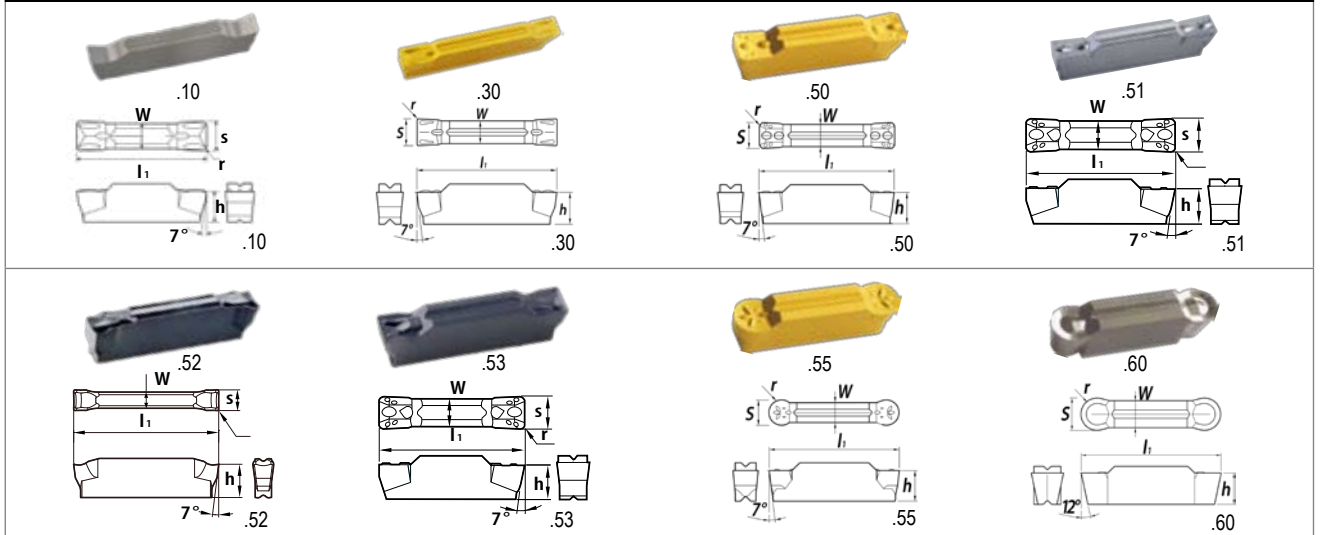

Bezeichnung Part Number	Lager Stock				s mm	r mm	l ₁ mm	w mm	h mm	Klemmhaltertyp Toolholder Type
	GK 1110	GK 1210	GP 2120	GM 5130						
216. 0150. 10 -D		○			1.5	0.15	16	1.2	3.5	.015
216. 0150. 30 -DM				●						
new! 216. 0150. 52 -DM					2.0	0.2	16	1.6	3.5	.02
216. 0200. 10 -D		●								
216. 0200. 30 -DM				●	2.0	0.2	16	1.6	3.5	.02
216. 0200. 30 -DP				●						
new! 216. 0200. 52 -DM				●	2.0	1.0	16	1.6	3.5	.02
216. 0200. 53 -DT				●						
216. 0200. 55 -D			○		2.0	1.0	16	1.6	3.5	.02
216. 0200. 55 -DM				●						
218. 0250. 10 -D		○			2.5	0.2	18.5	2.0	3.8	.025
218. 0250. 50 -DM				●						
218. 0250. 50 -DP			○		2.5	0.2	18.5	2.0	3.8	.025
222. 0300. 10 -D			●							
222. 0300. 50 -DM				●	3.0	0.4	21	2.35	4.8	.03
222. 0300. 50 -DP				●						
222. 0300. 52 -DM				●	3.0	0.4	21	2.35	4.8	.03
222. 0300. 53 -DT				●						
222. 0300. 55 -DM				●	3.0	1.5	21	2.35	4.8	.03
222. 0300. 55 -DP				●						
222. 0400. 50 -DM				●	4.0	0.4	26	3.3	5.8	.04
222. 0400. 50 -DP				●						
222. 0400. 51 -D		○			4.0	0.4	26	3.3	5.8	.04
222. 0400. 52 -DM				●						
222. 0400. 53 -DT				●	4.0	2.0	26	3.3	5.8	.04
222. 0400. 55 -DM				●						
222. 0400. 55 -DP				●	4.0	2.0	26	3.3	5.8	.04
226. 0500. 50 -DM				●						
226. 0500. 50 -DP				●	5.0	0.8	26	4.1	5.8	.05
226. 0500. 51 -D		○								
226. 0500. 55 -DM				○	5.0	2.5	26	4.1	5.8	.05
226. 0500. 55 -DP				●						
226. 0600. 10 -D		○			6.0	0.8	26	5.0	5.8	.06
226. 0600. 50 -DM				○						
226. 0600. 50 -DP				○	6.0	3.0	26	5.0	5.8	.06
226. 0600. 55 -DP				○						
232. 0800. 10 -D					8.0	0.8	31	6.0	6.5	.08
232. 0800. 50 -DP										
232. 0800. 51 -D		○			8.0	4.0	31	6.0	6.5	.08
232. 0800. 60 -D		○								
R216. 0150. 52 -D6				●	3.5	0.2	16	1.5	-	.015
R216. 0200. 52 -D6				●	3.5	0.2	16	2.0	-	.02
R222. 0300. 52 -D6				●	4.8	0.2	22	3.0	-	.03

R/L 240

System 217

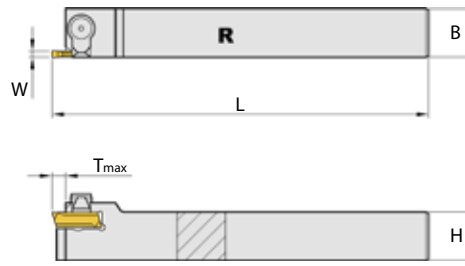

Drehen
Turning

Fräswerkzeuge
Milling Tools

HDS-/VHM- Fräser
HDS-/ Solid Carbide
Endmills

Stech- und
Abstechwerkzeuge
Grooving and
Parting off Tools

Mini/ Micro
Schneidwerkzeuge
Mini/ Micro Tools

Gewinde-
werkzeuge
Threading Tools

Wendepplattenbohrer
VHM-Bohrer
Indexable Drills
Solid Carbide Drills

Bezeichnung Part Number	Lager Stock		Maße [mm] Dimensions				Seite / Page: 4.14-4.15	Ersatzteile <i>Spare Parts</i>		
	R	L	H	B	L	T _{max}		W [mm]		
R/L 240. 1010. 01			10	10	80	4	0.5 - 1.7	32.10.709	32.10.109	48.12.604
R/L 240. 1212. 01			12	12	100	4				
R/L 240. 1414. 01			14	14	100	4				
R/L 240. 1616. 01			16	16	125	4				
R/L 240. 2020. 01			20	20	125	4				
R/L 240. 1010. 02			10	10	80	4	1.7 - 2.7			
R/L 240. 1212. 02			12	12	100	4				
R/L 240. 1414. 02			14	14	100	4				
R/L 240. 1616. 02			16	16	125	4				
R/L 240. 2020. 02			20	20	125	4				
R/L 240. 1010. 03			10	10	80	4	2.7 - 3.7			
R/L 240. 1212. 03			12	12	100	4				
R/L 240. 1414. 03			14	14	100	4				
R/L 240. 1616. 03			16	16	125	4				
R/L 240. 2020. 03			20	20	125	4				
R/L 240. 1010. 04			10	10	80	4	3.7 - 5.3			
R/L 240. 1212. 04			12	12	100	4				
R/L 240. 1414. 04			14	14	100	4				
R/L 240. 1616. 04			16	16	125	4				
R/L 240. 2020. 04			20	20	125	4				

Ausführung R oder L angeben / state R or L version

R/L 233

System 217

Drehen
Turning

Fräswerkzeuge
Milling Tools

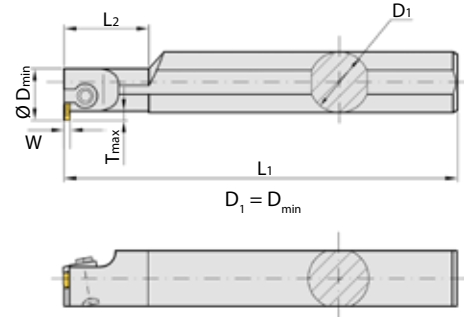

HDS-/VHM-Fräser
HDS-/Solid Carbide
Endmills

Stech- und
Abstechwerkzeuge
Grooving and
Parting off Tools

Bezeichnung Part Number	Lager Stock		Maße [mm] Dimensions				Seite / Page: 4.14-4.15	Ersatzteile Spare Parts		
	R	L	D ₁	L ₁	L ₂	T _{max}		W [mm]		
R/L 233. 0020. 01			20	130	25	3.0	0.5 - 1.7			
R/L 233. 0025. 01			25	150	30	4.7				
R/L 233. 0032. 01			32	150	30	4.7				
R/L 233. 0020. 02			20	130	25	3.0	1.7 - 2.7			
R/L 233. 0025. 02			25	150	30	4.7				
R/L 233. 0032. 02			32	150	30	4.7				
R/L 233. 0020. 03			20	130	25	3.0	2.7 - 3.7			
R/L 233. 0025. 03			25	150	30	4.7				
R/L 233. 0032. 03			32	150	30	4.7				
R/L 233. 0020. 04			20	130	25	3.0	3.7 - 5.3			
R/L 233. 0025. 04			25	150	30	4.7				
R/L 233. 0032. 04			32	150	30	4.7				

Ausführung R oder L angeben / state R or L version

Mini/Micro
Schneidwerkzeuge
Mini/Micro Tools

Gewinde-
werkzeuge
Threading Tools

Wendepplattenbohrer
VHM-Bohrer
Indexable Drills
Solid Carbide Drills

R/L 245

System 217

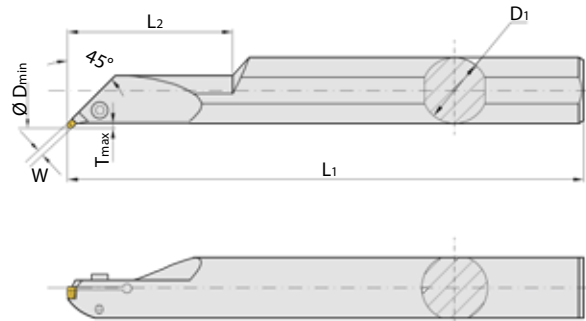

Bezeichnung Part Number	Lager Stock		Maße [mm] Dimensions				Seite / Page: 4.14-4.15	Ersatzteile Spare Parts		
	R	L	D ₁	L ₁	L ₂	D _{min}		W [mm]		
R/L 245. 0020. 02			20	180	60	20	1.7 - 2.7			
R/L 245. 0032. 02			32	250	80	31				
R/L 245. 0020. 03			20	180	60	20	2.7 - 3.7			
R/L 245. 0032. 03			32	250	80	31				
R/L 245. 0020. 04			20	180	60	20	3.7 - 5.3			
R/L 245. 0032. 04			32	250	80	31				

Ausführung R oder L angeben / state R or L version

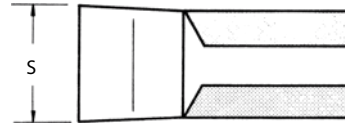

Bezeichnung Part Number	Lager Stock		Nut-Nennmaß Groove DIN-No. mm	s -0.05 mm	Klemmhalter-Typ Toolholder Type
	GK 1110	GP 5125			
217. 0050. 00		○	0.5	0.57	
217. 0060. 00		○	0.6	0.67	
217. 0070. 00		○	0.7	0.77	
217. 0080. 00		○	0.8	0.87	
217. 0090. 00		○	0.9	0.97	
217. 0100. 00		●	1.0	1.07	
217. 0110. 00		●	1.1	1.24	
217. 0130. 00		●	1.3	1.44	
217. 0160. 00		●	1.6	1.74	
217. 0185. 00		●	1.85	1.99	
217. 0215. 00		○	2.15	2.29	.02
217. 0265. 00		○	2.65	2.79	
217. 0315. 00		○	3.15	3.29	
217. 0415. 00		○	4.15	4.29	
217. 0515. 00		○	5.15	5.29	.04

Wendeschneidplatten sind in rechten und linken Klemmhaltern sowie Bohrstängen verwendbar.
Inserts can be used in RH and LH toolholders as well as in boring bars.

Bei Zwischenmaßen bitte WSP-Toleranz angeben.
When ordering different dimensions, please state tolerances.

Drehen
Turning

Fräswerkzeuge
Milling Tools

HDS-/VHM- Fräser
HDS-/Solid Carbide
Endmills

Stech- und
Abstechwerkzeuge
Grooving and
Parting off Tools

Mini/ Micro
Schneidwerkzeuge
Mini/ Micro Tools

Gewinde-
werkzeuge
Threading Tools

Wendepplattenbohrer
VHM-Bohrer
Indexable Drills
Solid Carbide Drills

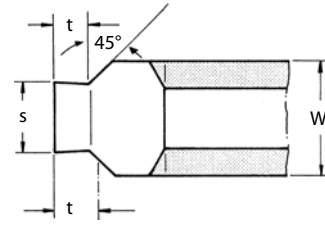

Drehen
Turning

Fräswerkzeuge
Milling Tools

HDS-/VHM-Fräser
HDS-/Solid Carbide
Endmills

Stech- und
Abstechwerkzeuge
Grooving and
Parting off Tools

Mini/Micro
Schneidwerkzeuge
Mini/Micro Tools

Gewinde-
werkzeuge
Threading Tools

Wendepplattenbohrer
VHM-Bohrer
Indexable Drills
Solid Carbide Drills

Bezeichnung Part Number	Lager Stock		Nut-Nennmaß Groove DIN-No. mm	s -0.05 mm	t ₁ -0.05 mm	t mm	w mm	Klemmhalter-Typ Toolholder Type
	GK 1110	GP 5125						
217. 1101. 25			1.1	1.24	0.19	0.20	2.5	.02
217. 1102. 25			1.1	1.24	0.24	0.25		
217. 1103. 25			1.1	1.24	0.29	0.30		
217. 1104. 25			1.1	1.24	0.33	0.35		
217. 1105. 25			1.1	1.24	0.36	0.40		
217. 1306. 25			1.3	1.44	0.45	0.55		
217. 1607. 33			1.6	1.74	0.60	0.70	3.3	.03
217. 1608. 33			1.6	1.74	0.75	0.85		
217. 1609. 33			1.6	1.74	0.85	1.00		
217. 1810. 33			1.85	1.99	0.85	1.00		
217. 1812. 33			1.85	1.99	1.10	1.25		
217. 2115. 43			2.15	2.29	1.35	1.50	4.3	.04
217. 2616. 43			2.65	2.79	1.35	1.50		
217. 2617. 43			2.65	2.79	1.60	1.75		
217. 3118. 53			3.15	3.29	1.60	1.75		
217. 4120. 53			4.15	4.29	1.85	2.00	5.3	
217. 4125. 53			4.15	4.29	2.35	2.50		

Wendeschneidplatten sind in rechten und linken Klemmhaltern sowie Bohrstäben verwendbar.
Inserts can be used in RH and LH toolholders as well as in boring bars.

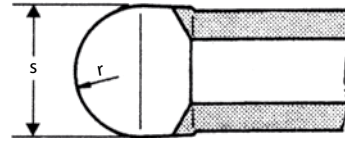

Drehen
Turning

Fräswerkzeuge
Milling Tools

HDS-/VHM-Fräser
HDS-/Solid Carbide
Endmills

Stech- und
Abstechwerkzeuge
Grooving and
Parting off Tools

Mini/ Micro
Schneidwerkzeuge
Mini/ Micro Tools

Gewinde-
werkzeuge
Threading Tools

Wendepplattenbohrer
VHM-Bohrer
Indexable Drills
Solid Carbide Drills

Bezeichnung Part Number	Lager Stock		r	s	Klemmhalter-Typ Toolholder Type
	GK 1110	GP 5125	mm	mm	

für Nuten DIN 7993 for Grooves DIN 7993

217. 1305. 00			0.5	1.3	.01
217. 1306. 00			0.6	1.3	

für Eckenfreistriche for Corner Reliefs

217. 0010. 20		○	1.0	2.0	.02
217. 0015. 30			1.5	3.0	.03
217. 0020. 40			2.0	4.0	.04
217. 0025. 50			2.5	5.0	.04

Wendeschneidplatten sind in rechten und linken Klemmhaltern sowie Bohrstängen verwendbar.
Inserts can be used in RH and LH toolholders as well as in boring bars.

Drehen
Turning

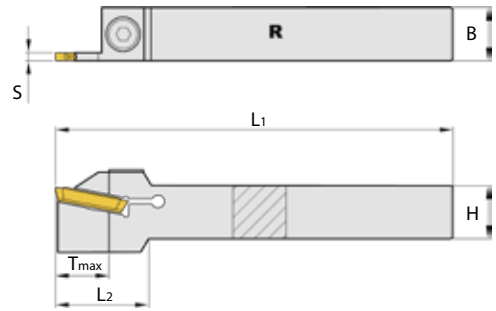
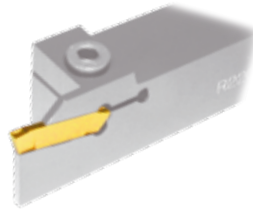

Fräswerkzeuge
Milling Tools

HDS-/VHM-Fräser
HDS-/Solid Carbide
Endmills

Stech- und
Abstechwerkzeuge
Grooving and
Parting off Tools

Mini/Micro
Schneidwerkzeuge
Mini/Micro Tools

Gewinde-
werkzeuge
Threading Tools

Wendepplattenbohrer
VHM-Bohrer
Indexable Drills
Solid Carbide Drills

Bezeichnung Part Number	Lager Stock		Maße [mm] Dimensions				Seite / Page: 4.20 s [mm]	Ersatzteile Spare Parts										
	R	L	H=B	L ₁	L ₂	T _{max}												
R/L 220. 1616. 02			16	100	35	20	2.0 - 2.9	32.20.116	32.20.616	32.20.517								
R/L 220. 2020. 02	●	●	20	125	35	20												
R/L 220. 2525. 02		○	25	150	-	20												
R/L 220. 1616. 03			16	100	35	20	3.0 - 3.9			32.20.116	32.20.616	-						
R/L 220. 2020. 03	○	●	20	125	40	20												
R/L 220. 2525. 03	○	○	25	150	-	20												
R/L 220. 1616. 04			16	100	35	20	4.0 - 4.9					32.20.116	32.20.616	32.20.517				
R/L 220. 2020. 04	○	○	20	125	35	20												
R/L 220. 2525. 04	○	○	25	150	-	20												
R/L 220. 1616. 05			16	100	35	20	5.0 - 5.9								32.20.116	32.20.616	32.20.517	
R/L 220. 2020. 05			20	125	35	20												
R/L 220. 2525. 05			25	150	-	20												
R/L 220. 1616. 06			16	100	35	20	6.0 - 6.9	32.20.116	32.20.616									32.20.517
R/L 220. 2020. 06			20	125	35	20												
R/L 220. 2525. 06			25	150	-	20												

Ausführung R oder L angeben / state R or L version

R/L 225

System 229

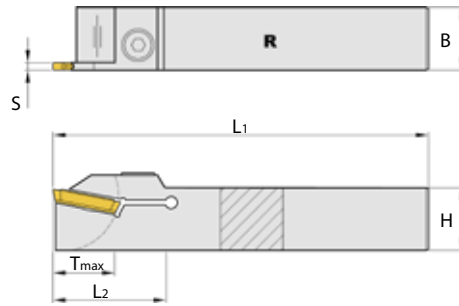

Bezeichnung Part Number	Lager Stock		Maße [mm] Dimensions					Seite / Page: 4.20 s [mm]	Ersatzteile Spare Parts		
	R	L	H	B	L ₁	L ₂	T _{max}				
R/L 225. 2020. 02			20	20	125	43	25	2.0 - 2.9	32.20.116	32.20.616	32.20.517
R/L 225. 2525. 02			25	25	150	-	25				
R/L 225. 3225. 02			32	25	170	-	25				
R/L 225. 2020. 03			20	20	125	43	25	3.0 - 3.9			
R/L 225. 2525. 03			25	25	150	-	25				
R/L 225. 3225. 03			32	25	170	-	25				
R/L 225. 2020. 04			20	20	125	43	25	4.0 - 4.9			
R/L 225. 2525. 04			25	25	150	-	25				
R/L 225. 3225. 04			32	25	170	-	25				
R/L 225. 2020. 05			20	20	125	43	25	5.0 - 5.9			
R/L 225. 2525. 05			25	25	150	-	25				
R/L 225. 3225. 05			32	25	170	-	25				
R/L 225. 2020. 06			20	20	125	43	25	6.0 - 6.9			
R/L 225. 2525. 06			25	25	150	-	25				
R/L 225. 3225. 06			32	25	170	-	25				

Ausführung R oder L angeben / state R or L version

Drehen
Turning

Fräswerkzeuge
Milling Tools

HDS-/VHM- Fräser
HDS-/Solid Carbide
Endmills

Stech- und
Abstechwerkzeuge
Grooving and
Parting off Tools

Mini/ Micro
Schneidwerkzeuge
Mini/ Micro Tools

Gewinde-
werkzeuge
Threading Tools

Wendepaltenbohrer
VHM-Bohrer
Indexable Drills
Solid Carbide Drills

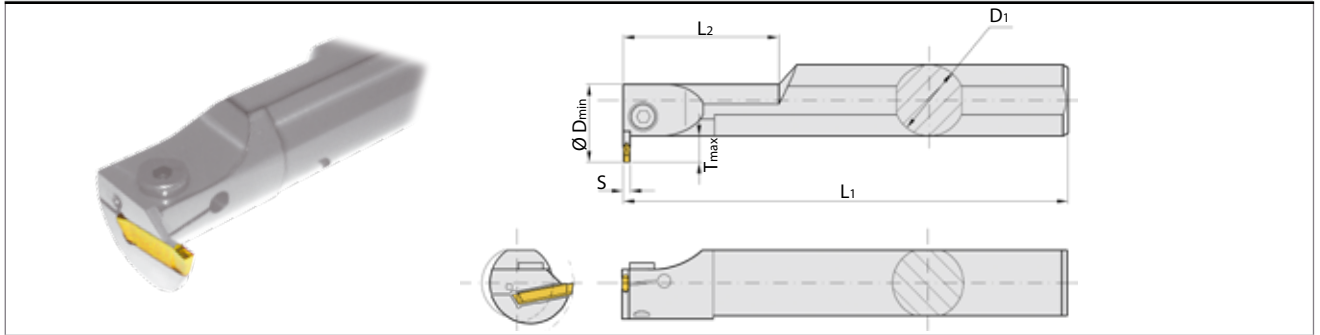

Bezeichnung Part Number	Lager Stock		Maße [mm] Dimensions					Seite / Page: 4.20 s [mm]	Ersatzteile Spare Parts		
	R	L	D ₁	L ₁	D _{min}	L ₂	T _{max}				
R/L 214. 0032. 02	○		32	200	46	-	11.5	2.0 - 2.9	32.20.116	32.20.616	32.20.517
R/L 214. 0040. 02			40	250	50	80	11.5				
R/L 214. 0050. 02			50	250	60	100	15.0				
R/L 214. 0032. 03	○		32	200	46	-	11.5	3.0 - 3.9			
R/L 214. 0040. 03			40	250	50	80	11.5				
R/L 214. 0050. 03			50	250	60	100	15.0				
R/L 214. 0032. 04			32	200	46	-	11.5	4.0 - 4.9			
R/L 214. 0040. 04			40	250	50	80	11.5				
R/L 214. 0050. 04			50	250	60	100	15.0				
R/L 214. 0032. 05			32	200	46	-	11.5	5.0 - 5.9			
R/L 214. 0040. 05			40	250	50	80	11.5				
R/L 214. 0050. 05			50	250	60	100	15.0				
R/L 214. 0032. 06			32	200	46	-	11.5	6.0 - 6.9			
R/L 214. 0040. 06			40	250	50	80	11.5				
R/L 214. 0050. 06			50	250	60	100	15.0				

Ausführung R oder L angeben / state R or L version

R/L 229

für Schwerzerspannung for Heavy Duty Groove

System 229

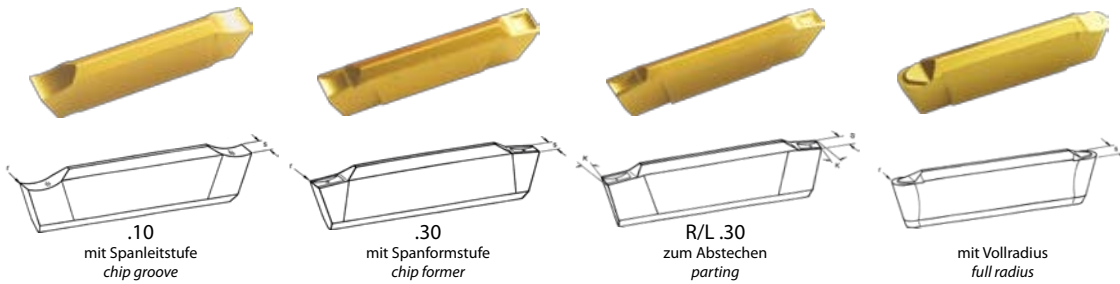

Bezeichnung Part Number	Lager Stock		s +0.05	r	Klemhaltertyp Toolholder Type		
	GK 1110	GP 5125	mm	mm			
229. 0200. 10	●	●	2.0	0.20	.02		
229. 0300. 10	●	●	3.0	0.20	.03		
229. 0400. 10			4.0	0.20	.04		
229. 0500. 10			5.0	0.40	.05		
229. 0600. 10			6.0	0.40	.06		
229. 0200. 30		●	2.0	0.20	.02		
229. 0300. 30		●	3.0	0.20	.03		
229. 0400. 30		○	4.0	0.20	.04		
229. 0500. 30		○	5.0	0.40	.05		
229. 0600. 30			6.0	0.40	.06		
	R	L	R	L			
R/L 229. 5200. 30					2.0	0.15	.02
R/L 229. 5300. 30			●	○	3.0	0.15	.03
R/L 229. 5400. 30					4.0	0.15	.04
229. 0010. 20					2.0	1.00	.02
229. 0015. 30					3.0	1.50	.03
229. 0020. 40					4.0	2.00	.04
229. 0025. 50					5.0	2.50	.05
229. 0030. 60					6.0	3.00	.06

Bei Zwischenmaßen bitte WSP-Toleranz angeben.
When ordering different dimensions, please state tolerances.

Drehen
Turning

Fräswerkzeuge
Milling Tools

HDS-/VHM-Fräser
HDS-/Solid Carbide
Endmills

Stech- und
Abstechwerkzeuge
Grooving and
Parting off Tools

Mini/ Micro
Schneidwerkzeuge
Mini/ Micro Tools

Gewinde-
werkzeuge
Threading Tools

Wendepplattenbohrer
VHM-Bohrer
Indexable Drills
Solid Carbide Drills

Drehen
Turning

Fräswerkzeuge
Milling Tools

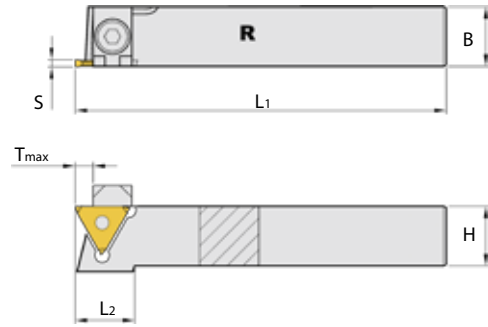

HDS-/VHM-Fräser
HDS-/Solid Carbide
Endmills

Stech- und
Abstechwerkzeuge
Grooving and
Parting off Tools

Mini/Micro
Schneidwerkzeuge
Mini/Micro Tools

Gewinde-
werkzeuge
Threading Tools

Wendepplattenbohrer
VHM-Bohrer
Indexable Drills
Solid Carbide Drills

Bezeichnung Part Number	Lager Stock		Maße [mm] Dimensions				Seite / Page: 4.24-4.28	Ersatzteile <i>Spare Parts</i>		
	R	L	H=B	L ₁	L ₂	T _{max}				
R/L 360. 1212. 01	●		12	100	24	4	0.5 - 1.9	<u>1212</u> 32.05.715	<u>1212</u> 32.15.115	<u>1212</u> 48.12.606
R/L 360. 1616. 01	●	●	16	125	22	4				
R/L 360. 2020. 01	●	●	20	125	21	4				
R/L 360. 2525. 01	●	●	25	150	-	4				
R/L 360. 1212. 02			12	100	24	6	1.9 - 2.9	<u>1616</u> 32.05.712	<u>1616</u> 32.15.114	<u>1616</u> 48.11.602
R/L 360. 1616. 02			16	125	22	6				
R/L 360. 2020. 02	●		20	125	21	6				
R/L 360. 2525. 02	●	●	25	150	-	6				
R/L 360. 1212. 03			12	100	24	6	2.9 - 3.9	<u>2020</u> 32.05.716	<u>2020</u> 32.15.114	<u>2020</u> 48.11.602
R/L 360. 1616. 03			16	125	22	6				
R/L 360. 2020. 03	●		20	125	21	6				
R/L 360. 2525. 03			25	150	-	6				
R/L 360. 1212. 04			12	100	24	6	3.9 - 6.3	<u>2525</u> 32.05.716	<u>2525</u> 32.15.114	<u>2525</u> 48.11.602
R/L 360. 1616. 04			16	125	22	6				
R/L 360. 2020. 04	●		20	125	21	6				
R/L 360. 2525. 04			25	150	-	6				

Ausführung R oder L angeben / state R or L version

R/L 390

System 312

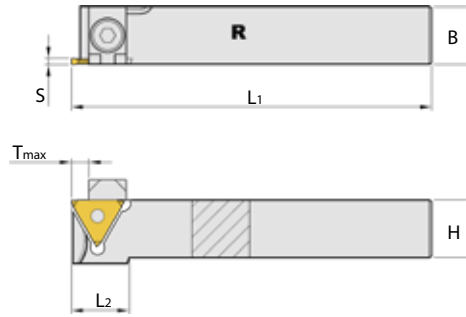
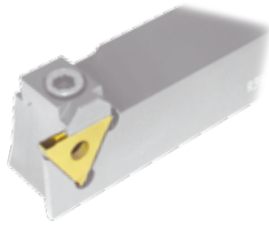

Drehen
Turning

Fräswerkzeuge
Milling Tools

HDS-/VHM-Fräser
HDS-/Solid Carbide
Endmills

Stech- und
Abstechwerkzeuge
Grooving and
Parting off Tools

Mini/ Micro
Schneidwerkzeuge
Mini/ Micro Tools

Gewinde-
werkzeuge
Threading Tools

Wendepplattenbohrer
VHM-Bohrer
Indexable Drills
Solid Carbide Drills

Bezeichnung Part Number	Lager Stock		Maße [mm] Dimensions				Seite / Page: 4.24-4.28	Ersatzteile Spare Parts		
	R	L	H=B	L ₁	L ₂	T _{max}		s [mm]		
R/L 390. 2020. 02	○		20	125	22	8	1.9 - 2.9			
R/L 390. 2525. 02	○		25	150	-	8				
R/L 390. 2020. 03			20	125	22	8	2.9 - 3.9			
R/L 390. 2525. 03			25	150	-	8				
R/L 390. 2020. 04			20	125	22	8	3.9 - 6.3			
R/L 390. 2525. 04			25	150	-	8				

Ausführung R oder L angeben / state R or L version

R/L 309

System 312

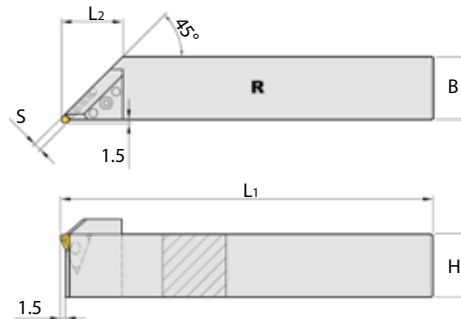

Bezeichnung Part Number	Lager Stock		Maße [mm] Dimensions			Seite / Page: 4.24-4.28	Ersatzteile Spare Parts			
	R	L	H=B	L ₁	L ₂		s [mm]			
R/L 309. 2020. 02			20	125	30	1.9 - 2.9				
R/L 309. 2525. 02			25	150	-					
R/L 309. 2020. 03			20	125	30	2.9 - 3.9				
R/L 309. 2525. 03			25	150	-					
R/L 309. 2020. 04			20	125	30	3.9 - 6.3				
R/L 309. 2525. 04			25	150	-					

Ausführung R oder L angeben / state R or L version

R/L 369

System 312

Drehen
Turning

Fräswerkzeuge
Milling Tools

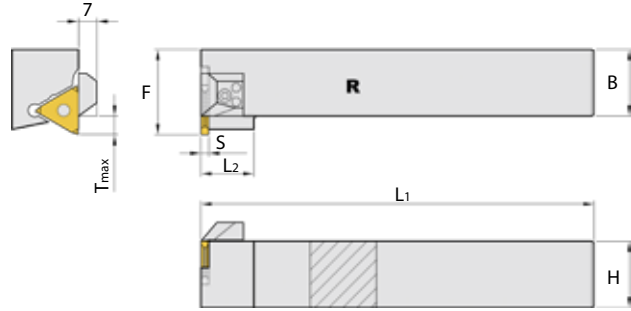

HDS-/VHM-Fräser
HDS-/Solid Carbide
Endmills

Stech- und
Abstechwerkzeuge
Grooving and
Parting off Tools

Bezeichnung Part Number	Lager Stock		Maße [mm] Dimensions				Seite / Page: 4.24-4.28	Ersatzteile Spare Parts				
	R	L	H=B	L ₁	L ₂	F		T _{max}	s [mm]			
R/L 369. 2020. 01			20	150	20	27	4	0.5 - 1.9	L 369 32.05.708			
R/L 369. 2525. 01			25	150	-	32	4					
R/L 369. 2020. 02			20	150	20	27	6	1.9 - 2.9				
R/L 369. 2525. 02			25	150	-	32	6					
R/L 369. 2020. 03			20	150	20	27	6	2.9 - 3.9	R 369 32.05.707			
R/L 369. 2525. 03			25	150	-	32	6					
R/L 369. 2020. 04			20	150	20	27	6	3.9 - 6.3				
R/L 369. 2525. 04			25	150	-	32	6					

Ausführung R oder L angeben / state R or L version

Mini/ Micro
Schneidwerkzeuge
Mini/ Micro Tools

Gewinde-
werkzeuge
Threading Tools

Wendepplattenbohrer
VHM-Bohrer
Indexable Drills
Solid Carbide Drills

R/L 330

System 312



D _{min} mm	Stechtiefe max. max. depth of groove mm
46	2
50	3
60	4
80	4.5
100	5

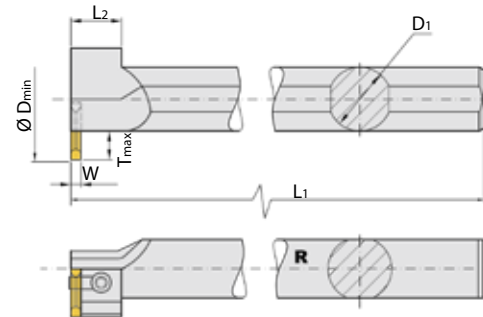
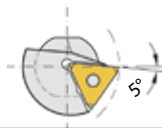

Bezeichnung Part Number	Lager Stock		Maße [mm] Dimensions				Seite / Page: 4.24-4.28	Ersatzteile Spare Parts			
	R	L	D ₁	L ₁	L ₂	D _{min}		s [mm]			
R/L 330. 0025. 01			25	300	20	46	0.5 - 1.9				
R/L 330. 0032. 01			32	350	20	46					
R/L 330. 0040. 01			40	400	-	46	1.9 - 2.9				
R/L 330. 0025. 02			25	300	20	46					
R/L 330. 0032. 02			32	350	20	46	2.9 - 3.9				
R/L 330. 0040. 02			40	400	-	46					
R/L 330. 0025. 03			25	300	20	46	3.9 - 6.3				
R/L 330. 0032. 03			32	350	20	46					
R/L 330. 0040. 03			40	400	-	46					
R/L 330. 0025. 04			25	300	20	46					
R/L 330. 0032. 04			32	350	20	46					
R/L 330. 0040. 04			40	400	-	46					

Ausführung R oder L angeben / state R or L version

312

für Sicherungsringe DIN 471/472 for Circlips DIN 471/472

System 312

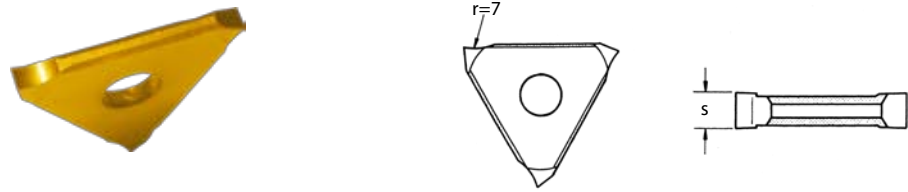

Bezeichnung Part Number	Lager Stock			Nut-Nennmaß Groove DIN-No. mm	s -0.05 mm	Klemmhalter-Typ Toolholder Type
	GK 1120	GK 5320	GP 5125			
312. 0050. 00	○	○	●	0.5	0.57	
312. 0060. 00	○	○	●	0.6	0.67	
312. 0070. 00	○	○	●	0.7	0.77	
312. 0080. 00	○	○	●	0.8	0.87	
312. 0090. 00	○	○	●	0.9	0.97	
312. 0100. 00	○	○	●	1.0	1.07	
312. 0110. 00	○	○	●	1.1	1.24	
312. 0130. 00	○	○	●	1.3	1,44	
312. 0160. 00			●	1.6	1.74	
312. 0185. 00			●	1.85	1.99	
312. 0215. 00			●	2.15	2.29	
312. 0265. 00			●	2.65	2.79	
312. 0315. 00	○	○	●	3.15	3.29	
312. 0415. 00		○	○	4.15	4.29	
312. 0515. 00			○	5.15	5.29	

Wendeschneidplatten sind in rechten und linken Klemmhaltern sowie Bohrstangen verwendbar.
Inserts can be used in RH and LH toolholders as well as in boring bars.

Bei Zwischenmaßen bitte WSP-Toleranz angeben.
When ordering different dimensions please state tolerances.

Drehen
Turning

Fräswerkzeuge
Milling Tools

HDS-/VHM- Fräser
HDS-/Solid Carbide
Endmills

Stech- und
Abstechwerkzeuge
Grooving and
Parting off Tools

Mini/ Micro
Schneidwerkzeuge
Mini/ Micro Tools

Gewinde-
werkzeuge
Threading Tools

Wendepaltenbohrer
VHM-Bohrer
Indexable Drills
Solid Carbide Drills

Drehen
Turning

Fräswerkzeuge
Milling Tools

HDS-/VHM-Fräser
HDS-/Solid Carbide
Endmills

Stech- und
Abstechwerkzeuge
Grooving and
Parting off Tools

Mini/Micro
Schneidwerkzeuge
Mini/Micro Tools

Gewinde-
werkzeuge
Threading Tools

Wendepplattenbohrer
VHM-Bohrer
Indexable Drills
Solid Carbide Drills

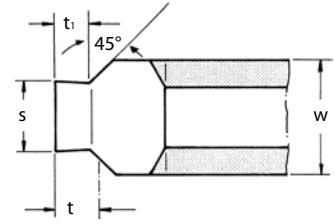

Bezeichnung Part Number	Lager Stock			Nut-Nennmaß Groove DIN-No. mm	s -0.05 mm	t ₁ -0.05 mm	t mm	w mm	Klemmhalter-Typ Toolholder Type
	GK 1120	GK 5320	GP 5125						
312. 1101. 25				1.1	1.24	0.19	0.20	2.5	.02
312. 1102. 25				1.1	1.24	0.24	0.25		
312. 1103. 25				1.1	1.24	0.29	0.30		
312. 1104. 25				1.1	1.24	0.33	0.35		
312. 1105. 25				1.1	1.24	0.36	0.40		
312. 1306. 25				1.3	1.44	0.45	0.55		
312. 1607. 33				1.6	1.74	0.60	0.70	3.3	.03
312. 1608. 33				1.6	1.74	0.75	0.85		
312. 1609. 33				1.6	1.74	0.85	1.00		
312. 1810. 33				1.85	1.99	0.85	1.00		
312. 1812. 33				1.85	1.99	1.10	1.25		
312. 2115. 43				2.15	2.29	1.35	1.50	4.3	.04
312. 2616. 43				2.65	2.79	1.35	1.50		
312. 2617. 43				2.65	2.79	1.60	1.75		
312. 3118. 53				3.15	3.29	1.60	1.75	5.3	
312. 4120. 53				4.15	4.29	1.85	2.00		
312. 4125. 53				4.15	4.29	2.35	2.50	6.3	
312. 5130. 63				5.15	5.29	2.85	3.00		

Wendeschneidplatten sind in rechten und linken Klemmhaltern sowie Bohrstäben verwendbar.
Inserts can be used in RH and LH toolholders as well as in boring bars.

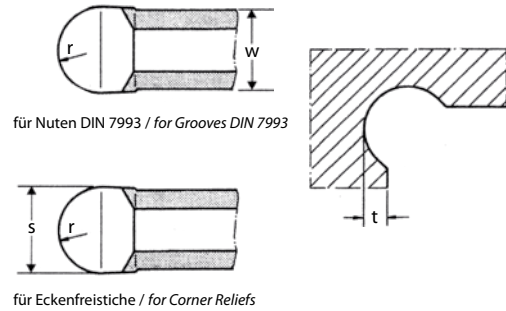
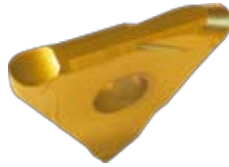

Drehen
Turning

Fräswerkzeuge
Milling Tools

HDS-/VHM-Fräser
HDS-/Solid Carbide
Endmills

Stech- und
Abstechwerkzeuge
Grooving and
Parting off Tools

Mini/ Micro
Schneidwerkzeuge
Mini/ Micro Tools

Gewinde-
werkzeuge
Threading Tools

Wendepplattenbohrer
VHM-Bohrer
Indexable Drills
Solid Carbide Drills

Bezeichnung Part Number	Lager Stock			r	s	t _{max}	w	Klemmhalter-Typ Toolholder Type
	GK 1120	GK 5320	GP 5125	mm	mm	mm	mm	

für Nuten DIN 7993 for Grooves DIN 7993

312. 1302. 00				0.2	0.4	0.6	1.3	.01
312. 1302. 05				0.25	0.5	0.85	1.3	
312. 1303. 00				0.3	0.6	1.1	1.3	
312. 1304. 00				0.4	0.8	2.3	1.3	
312. 1305. 00				0.5	1.0	2.5	1.3	
312. 1306. 00				0.6	1.2	0.8	1.3	
312. 0009. 18				0.9	1.8	4	1.2	
312. 0011. 22				1.1	2.2	6	1.6	
312. 0014. 28				1.4	2.8	6	2.2	
312. 0018. 36				1.8	3.6	6	3.0	

für Eckenfreistriche for Corner Reliefs

312. 0010. 20			○	1.0	2.0	0.7	1.4	.01
312. 0015. 30			○	1.5	3.0	1.0	2.4	.02
312. 0020. 40				2.0	4.0	1.2	3.4	.03
312. 0025. 50			○	2.5	5.0	1.5	4.4	.04
312. 0030. 60				3.0	6.0	1.8	5.4	

für CNC-Konturrenrehen for CNC shape grooving

312. 0100. 05			○	0.50	1.0		0.84	.01
312. 0150. 07				0.75	1.5		1.2	
312. 0200. 10			○	1.00	2.0		1.4	
312. 0250. 12				1.25	2.5		1.9	
312. 0300. 15				1.50	3.0		2.4	.02
312. 0400. 20				2.00	4.0		3.4	.03

Wendeschneidplatten sind in rechten und linken Klemmhaltern sowie Bohrstangen verwendbar - Stechtiefe ist halterabhängig.
Inserts can be used in RH and LH toolholders as well as in boring bars epth of groove in relation to toolholder.

R/L 312

zum Abstechen *for Parting-off*

System 312

Drehen
Turning

Fräswerkzeuge
Milling Tools

HDS-/VHM-Fräser
HDS-/Solid Carbide
Endmills

Stech- und
Abstechwerkzeuge
Grooving and
Parting off Tools

Mini/Micro
Schneidwerkzeuge
Mini/Micro Tools

Gewinde-
werkzeuge
Threading Tools

Wendepplattenbohrer
VHM-Bohrer
Indexable Drills
Solid Carbide Drills

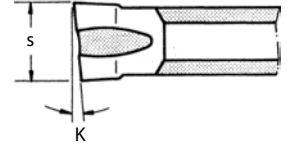
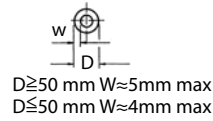
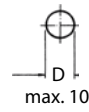

Bezeichnung Part Number	Lager Stock			s	K	Klemmhalter-Typ Toolholder Type
	GK 1120	GK 5320	GP 5125	mm		
	R L	R L	R L			
R/L 312. 0516. 00			○	1.6		.01
R/L 312. 0521. 00				2.1	5°	.02

Ausführung R oder L angeben / state R or L version.

Rechte Wendeschneidplatten in rechten und linke Wendeschneidplatten in linken Klemmhaltern verwenden.
RH inserts are to be used in RH and LH inserts in LH toolholders.

312

zum Feindrehen *for Finishing*

System 312

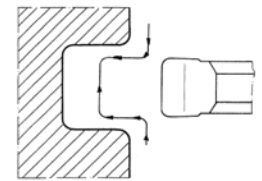
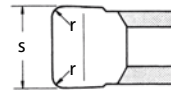

Bezeichnung Part Number	Lager Stock			s	r	Klemmhalter-Typ Toolholder Type
	GK 1120	GK 5320	GP 5125	mm	mm	
312. 0100. 02		○	●	1.0	0.2	.01
312. 0150. 02			○	1.5	0.2	
312. 0200. 02		○	○	2.0	0.2	
312. 0200. 04				2.0	0.4	
312. 0250. 02				2.5	0.2	
312. 0250. 04				2.5	0.4	
312. 0300. 02				3.0	0.2	
312. 0300. 06				3.0	0.6	
312. 0300. 08				3.0	0.8	
312. 0400. 02				4.0	0.2	
312. 0400. 08				4.0	0.8	.02
312. 0400. 12				4.0	1.2	

Wendeschneidplatten sind in rechten und linken Klemmhaltern sowie Bohrstangen verwendbar.
Inserts can be used in RH and LH toolholders as well as in boring bars.

R/L 312

zum Axialstechen *for Face Grooving*

System 312

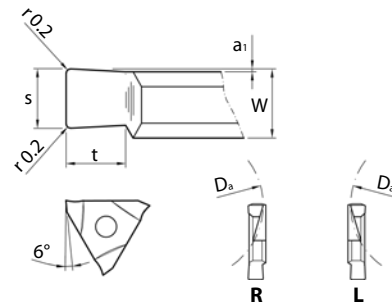
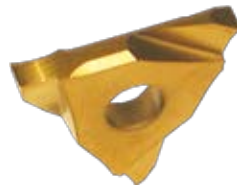

Drehen
Turning

Fräswerkzeuge
Milling Tools

HDS-/VHM-Fräser
HDS-/Solid Carbide
Endmills

Stech- und
Abstechwerkzeuge
Grooving and
Parting off Tools

Mini/ Micro
Schneidwerkzeuge
Mini/ Micro Tools

Gewinde-
werkzeuge
Threading Tools

Wendepplattenbohrer
VHM-Bohrer
Indexable Drills
Solid Carbide Drills

Bezeichnung Part Number	Lager Stock						s -0.05 mm	w	t _{max}	Nutenaußen-Ø Outer-Ø Da Ø ≥ mm	Klemmhalter-Typ Toolholder Type
	GK 1120 R	GK 1120 L	GK 5320 R	GK 5320 L	GP 5125 R	GP 5125 L					
R/L 312. 2015. 02							1.5	2.7	2.0	20	.02
R/L 312. 3020. 02							2.0	2.7	3.0	30	.02
R/L 312. 3030. 02							3.0	3.7	3.0	30	.03

Ausführung R oder L angeben / state R or L version.

Rechte Wendeschneidplatten in rechten und linke Wendeschneidplatten in linken Klemmhaltern verwenden.
RH inserts are to be used in RH and LH inserts in LH toolholders.

312

für Eckenfreistriche ähnlich DIN 509 Form F
for Corner Reliefs Similar to DIN 509 type F

System 312

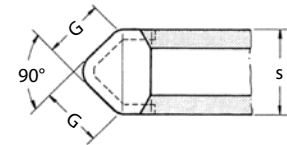
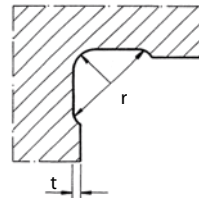
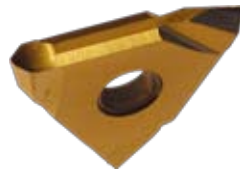

Bezeichnung Part Number	Lager Stock			r mm	t mm	G mm	s +/-0.05 mm	Klemmhalter-Typ Toolholder Type
	GK 1120	GK 5320	GP 5125					
312. 0602. 24				0.6	0.2	1.7	2.4	.02
312. 0603. 33				0.6	0.3	2.3	3.3	.03
312. 1002. 30				1.0	0.2	2.1	3.0	.04
312. 1004. 50				1.0	0.4	3.6	5.0	
312. 1603. 50				1.6	0.3	3.6	5.0	

Wendeschneidplatten sind in rechten und linken Klemmhaltern sowie Bohrstangen verwendbar.
Inserts can be used in RH and LH toolholders as well as in boring bars.

SMBB

Spannblöcke *Blocks*

System LGTN

Drehen
Turning



SMBB

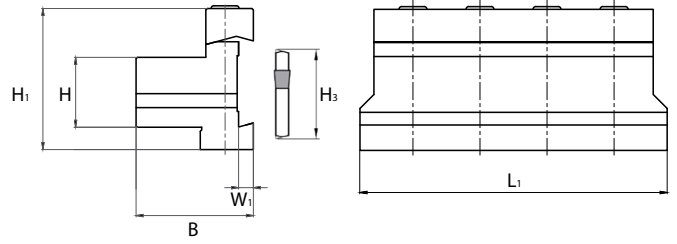

Fräswerkzeuge
Milling Tools

HDS-/VHM-Fräser
HDS-/Solid Carbide
Endmills

Stech- und
Abstechwerkzeuge
Grooving and
Parting off Tools

Mini/Micro
Schneidwerkzeuge
Mini/Micro Tools

Gewinde-
werkzeuge
Threading Tools

Wendepplattenbohrer
VHM-Bohrer
Indexable Drills
Solid Carbide Drills

Bezeichnung Part Number	Lager Stock	Maße [mm] Dimensions						Seite / Page: 4.31	Ersatzteile <i>Spare Parts</i>	
		H	H ₃	L ₁	H ₁	B	W ₁			
SMBB 0819	●	08	19	56	30	25	1.6	Seite / Page: 4.31		
SMBB 1019	●	10	19	56	30	25	1.6			
SMBB 1219	●	12	19	56	30	25	1.6			
SMBB 1619	●	16	19	76	30	26	1.6			
SMBB 1626	●	16	26	86	32	32	5.3	Seite / Page: 4.31		
SMBB 2026	●	20	26	86	38	38	5.3			
SMBB 2032	○	20	32	100	38	38	5.3			
SMBB 2526	●	25	26	86	42	42	5.3			
SMBB 2532	●	25	32	110	42	42	5.3	Seite / Page: 4.31		
SMBB 3232	○	32	32	110	48	48	5.3			

LGIH-S

Stechschwert *Blade*

System LGTN



LGIH 26-3S

mit Stoppanschlag / stopper type

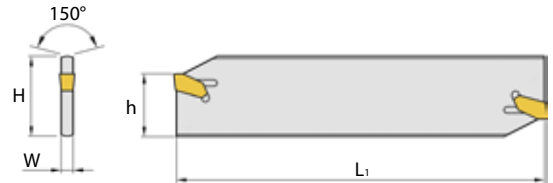

Bezeichnung Part Number	Lager Stock	Maße [mm] Dimensions						Seite / Page: 4.31	Ersatzteile <i>Spare Parts</i>	
		H	W	L ₁	h	D _{max}				
LGIH 19-2 S	●	19	1.6	86	16	40	Seite / Page: 4.31			
LGIH 26-2 S	●	26	1.6	110	21	50				
LGIH 26-3 S	●	26	2.4	110	21	80				
LGIH 26-4 S	●	26	3.2	110	21	80				
LGIH 26-5 S	●	26	4.0	110	21	80				
LGIH 32-2 S	●	32	1.6	150	25	100				
LGIH 32-3 S	●	32	2.4	150	25	100				
LGIH 32-4 S	●	32	3.2	150	25	100				
LGIH 32-5 S	●	32	4.0	150	25	100				
LGIH 32-6 S	○	32	5.2	150	25	100				
NGIH 19-2	●	19	1.6	86	16	40				
NGIH 26-2	●	26	2.4	110	21	50				
NGIH 32-2	●	32	2.4	150	25	40				

LGIH-S IK

Stechschwert mit Innenkühlung Blade with Internal coolant

System LGTN

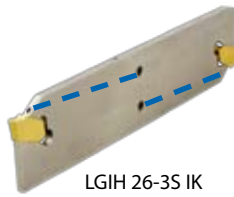

LGIH 26-3S IK

mit Stoppanschlag /stopper type

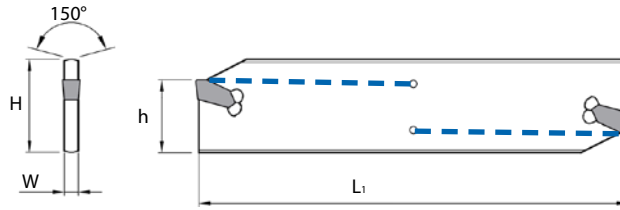

Drehen
Turning

Fräswerkzeuge
Milling Tools

HDS-/VHM-Fräser
HDS-/Solid Carbide
Endmills

Stech- und
Abstechwerkzeuge
Grooving and
Parting off Tools

Mini/ Micro
Schneidwerkzeuge
Mini/ Micro Tools

Gewinde-
werkzeuge
Threading Tools

Wendepplattenbohrer
VHM-Bohrer
Indexable Drills
Solid Carbide Drills

Bezeichnung Part Number	Lager Stock	Maße [mm] Dimensions					Seite / Page: 4.31	Ersatzteile Spare Parts		
		H	W	L ₁	h	D _{max}				
LGIH 26 - 3 S IK	●	26	2.4	110	21	80	LGT. - 3			
LGIH 32 - 3 S IK	●	32	2.4	150	25	100	LGT. - 3		32.30.601	

Fragen Sie auch nach den passenden VDI-Aufnahmen.
Please, ask also for suitable VDI-Blocks.

LGIP-S IK2

Stechschwert mit doppelter IK Blade with double IC

System LGTN

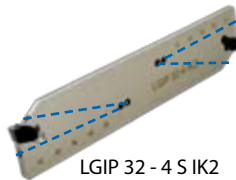

LGIP 32 - 4 S IK2

mit Stoppanschlag /stopper type

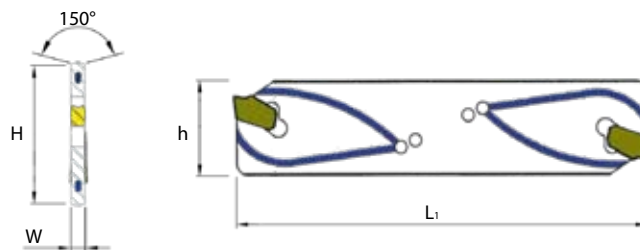

Bezeichnung Part Number	Lager Stock	Maße [mm] Dimensions					Seite / Page: 4.31	Ersatzteile Spare Parts		
		H	W	L ₁	h	D _{max}				
LGIP 26 - 3 S IK2	●	26	2.4	110	21	80	LGT. - 3			
LGIP 26 - 4 S IK2	●	26	3.2	110	21	80	LGT. - 4			
LGIH 32 - 3 S IK2	●	32	2.4	150	25	100	LGT. - 3	32.30.601	56.44.142	48.13.303
LGIH 32 - 4 S IK2	●	32	3.2	150	25	100	LGT. - 4			

Bitte fragen Sie auch nach unseren Spannblöcken für innengekühlte Schwerter.
Please ask also for blocks for blades with internal coolant.

LPH

Abstech-Halter Parting-off Toolholders

System LGTN

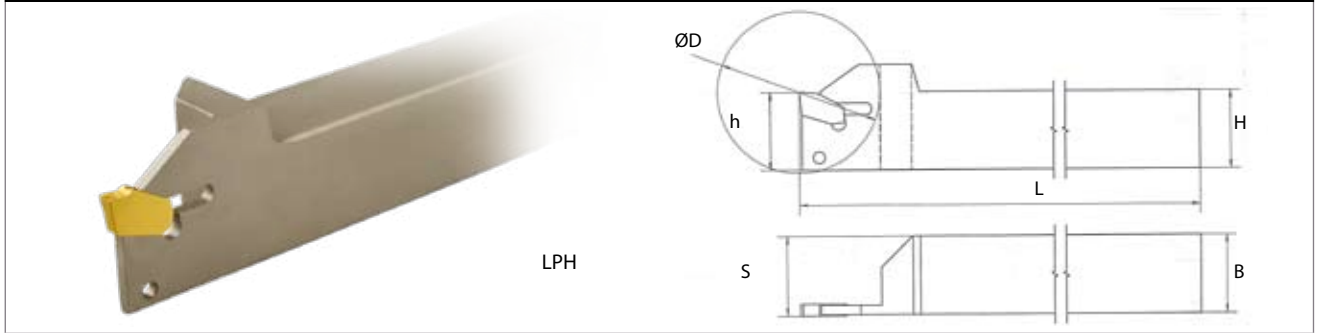

Drehen
Turning

Fräswerkzeuge
Milling Tools

HDS-/VHM-Fräser
HDS-/Solid Carbide
Endmills

Stech- und
Abstechwerkzeuge
Grooving and
Parting off Tools

Mini/Micro
Schneidwerkzeuge
Mini/Micro Tools

Gewinde-
werkzeuge
Threading Tools

Wendepplattenbohrer
VHM-Bohrer
Indexable Drills
Solid Carbide Drills

Bezeichnung Part Number	Lager Stock	Maße [mm] Dimensions						Seite / Page: 4.31	Ersatzteile Spare Parts
		H	B	L	S	h	D		
LPH 320 L - S	●	20	20	120	20.3	20	40	LGT. - 3	 32.30.605
LPH 320 R - S	●	20	20	120	20.3	20	40	LGT. - 3	
LPH 420 L - S	●	20	20	120	20.4	20	50	LGT. - 4	
LPH 420 R - S	●	20	20	120	20.4	20	50	LGT. - 4	

LGT. / NGT.

Abstech - Einsätze Inserts for Parting-off

System LGTN

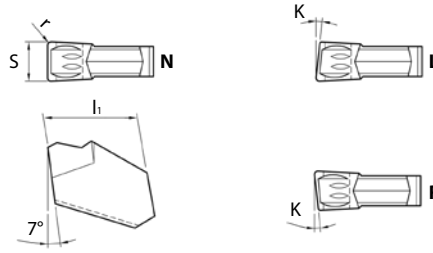
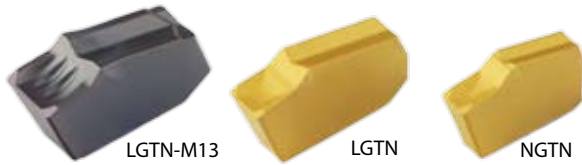

Drehen
Turning

Fräswerkzeuge
Milling Tools

HDS-/VHM-Fräser
HDS-/Solid Carbide
Endmills

Stech- und
Abstechwerkzeuge
Grooving and
Parting off Tools

Mini/ Micro
Schneidwerkzeuge
Mini/ Micro Tools

Gewinde-
werkzeuge
Threading Tools

Wendepplattenbohrer
VHM-Bohrer
Indexable Drills
Solid Carbide Drills

Bezeichnung Part Number	Lager Stock			s ± 0,05 - 0,10 mm	l ₁ ± 0,10 mm	r mm	K	
	GP 2120	GP 2235	GM 5130					
LGTL - 2							8°	LGIH .. - 2
LGTN - 2 - M13	●			2.2	8.8	0.15	8°	
LGTR - 2							8°	
LGTL - 3		●					8°	LGIH .. - 3
LGTN - 3 - M13	●		●	3.1	10.8	0.18	8°	LGIH .. - 3
LGTR - 3		●					8°	LPH .. - 3
LGTL - 4		○					8°	LGIH .. - 4
LGTN - 4 - M13	●		●	4.1	10.8	0.23	8°	LGIH .. - 4
LGTR - 4		●					8°	LPH .. - 4
LGTL - 5							8°	
LGTN - 5		●		5.1	11.0	0.23	8°	LGIH .. - 5
LGTR - 5							8°	
LGTL - 6							8°	
LGTN - 6				6.4	11.0	0.35	8°	LGIH .. - 6
LGTR - 6							8°	
NGTL - 2							8°	
NGTN - 2		●		2.2	8.8	0.20	8°	NGIH .. - 2
NGTR - 2							8°	

Innenbearbeitung Internal Grooving

Bohrungs- Ø <i>Bore - Ø</i> mm	Stechtiefe, max. <i>Depth of groove, max.</i> mm	Typ <i>Type</i>	Seite <i>Page</i>
≥ 20	3.0 / 4.7	217	4.12
≥ 20	3.5 / 4 / 5 / 6 / 6.5 / 8 / 10	216 / 218 222 / 226 / 232	4.08
≥ 46	11.5 / 15	229	4.18
≥ 46	2 / 3 / 4 / 5	312	4.22

Aussenbearbeitung External Grooving

Stechbreite <i>Width of groove</i> mm	Stechtiefe, max. <i>Depth of groove, max.</i> mm	Typ <i>Type</i>	Seite <i>Page</i>
0.5 - 5.3	4	217	4.11
0.5 - 6.3	8	312	4.20
2 - 6	12 / 20 / 25	229	4.16
1.5 - 8	12 / 14.5 / 18 / 23 / 25	216 / 218 222 / 226 / 232	4.04

Axialbearbeitung Face Grooving

Nutaußen - Ø <i>Outer - Ø of groove</i> mm	Nutbreite <i>Width of groove</i> mm	Nuttiefe <i>Depth of groove</i> mm	Typ <i>Type</i>	Seite <i>Page</i>
≥ 20	1.5	2	312	4.20
≥ 30	2.0 / 3.0	3	312	4.20
34 - 150	3.0	17	222	4.07
50 - 150	4.0	22		
70 - 200	5.0	25	226	

Schnittdaten-Empfehlungen zum Stechdrehen / Abstechen Cutting Data Recommendations for Grooving / Parting off

	Werkstückwerkstoff <i>Material</i>	Legierung <i>Alloy</i>	Schnittgeschwindigkeiten v_c [m/min] <i>Cutting Speeds v_c [m/min]</i>						
			GK 1110	GK 1120	GK 5320	GP 2120	GP 2235	GP 5125	GM 5125 GM 5130
A (P)	Unlegierter Stahl <i>Mild steel</i>	geglüht / <i>annealed</i> $\leq 0,15\% C$	-	-	120 - 200	120 - 200	80 - 160	120 - 200	100 - 180
		geglüht / <i>annealed</i> 0,15% - 0,45% C	-	-	100 - 200	100 - 200	80 - 160	100 - 200	100 - 180
		vergütet / <i>heat treated</i> $\geq 0,45\% C$	-	-	90 - 200	90 - 180	70 - 150	90 - 180	80 - 160
	Legierter Stahl <i>Alloyed steel</i>	niedrig / <i>low</i>	-	-	100 - 200	100 - 200	100 - 180	100 - 200	100 - 200
		mittel / <i>medium</i>	-	-	90 - 160	90 - 160	80 - 140	90 - 160	80 - 150
		hoch / <i>high</i>	-	-	70 - 100	70 - 100	70 - 100	70 - 100	70 - 100
R (M)	Rostfreier Stahl <i>Stainless steel</i>	austenitisch	-	-	50 - 160	50 - 160	30 - 140	50 - 160	30 - 150
		martensitisch	-	-	50 - 200	50 - 200	30 - 160	50 - 200	30 - 180
F (K)	Grauguss <i>Grey cast iron</i>		60 - 100	60 - 90	70 - 160	-	-	70 - 160	-
N	Aluminium	nicht aushärtbar <i>not hardenable</i>	800 - 1000	700 - 850	200 - 1200	-	-	200 - 1200	-
		aushärtbar <i>hardenable</i>	250 - 450	250 - 400	250 - 800	-	-	250 - 800	-
		> 12% Si	200 - 300	200 - 250	400 - 1000	-	-	400 - 1000	-
	Bronze, Messing, Rotguss <i>Bronze, brass, red brass</i>		90 - 200	90 - 180	90 - 200	-	-	90 - 200	-
S	Warmfeste Legierungen, Ni-Basis <i>Heat resistant alloys, Ni-base</i>		-	20 - 60	30 - 80	-	-	30 - 80	25 - 60
H	Gehärteter Stahl <i>Hardened steel</i>		10 - 20	-	-	-	-	-	-

WSP-Typ <i>Type of Insert</i>	Vorschübe (je nach Stechbreite) [mm/U] <i>Feeds (acc. to width of insert) [mm/rev]</i>
217	0.02 - 0.10
216 / 218 / 222 / 226 / 232	0.06 - 0.24
229	0.06 - 0.20
312	0.02 - 0.15

Richtwerte für Schnittgeschwindigkeit und Vorschübe bei Verwendung von Emulsion als Kühlschmiermittel.
Recommendations for cutting speed and feed when using coolants.

Drehen
Turning

Fräswerkzeuge
Milling Tools

HDS-/VHM-Fräser
HDS-/Solid Carbide
Endmills

Stech- und
Abstechwerkzeuge
Grooving and
Parting off Tools

Mini/ Micro
Schneidwerkzeuge
Mini/ Micro Tools

Gewinde-
werkzeuge
Threading Tools

Wendepflanzenbohrer
VHM-Bohrer
Indexable Drills
Solid Carbide Drills

R/L 275

System 275

Drehen
Turning

Fräswerkzeuge
Milling Tools

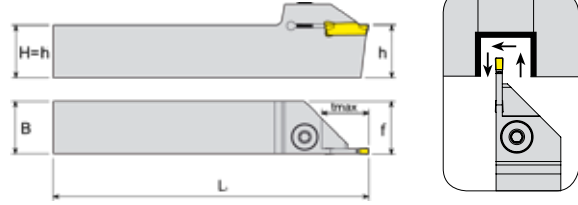

HDS-/VHM-Fräser
HDS-/Solid Carbide
Endmills

Stech- und
Abstechwerkzeuge
Grooving and
Parting off Tools

Bezeichnung Part Number	Lager Stock		Maße [mm] Dimensions				Seite / Page: 4.35	Ersatzteile Spare Parts			
	R	L	H=B	L ₁	f	T _{max}					
R/L 275. 1212. 03	•	•	12	125	12.3	16	SDGN/R 3102				
R/L 275. 1616. 03	•	•	16	125	16.3	19				32.30.113	48.12.606
R/L 275. 2020. 03	•	•	20	125	20.3	20					
R/L 275. 2525. 03	•	•	25	150	25.3	22				32.30.112	48.12.602

Ausführung R oder L angeben / state R or L version

Mini/Micro
Schneidwerkzeuge
Mini/Micro Tools

Gewinde-
werkzeuge
Threading Tools

Wendepplattenbohrer
VHM-Bohrer
Indexable Drills
Solid Carbide Drills

DGIH

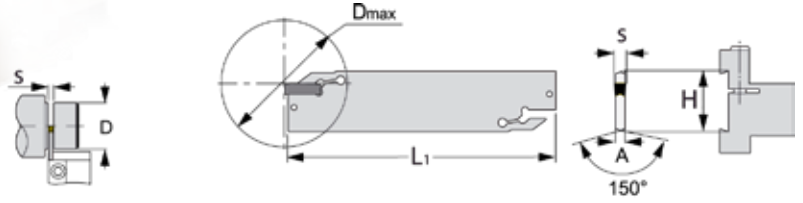

Bezeichnung Part Number	Lager Stock		Maße [mm] Dimensions						Seite / Page: 4.35	Ersatzteile Spare Parts	
	H	W	S	L ₁	D _{max}						
DGIH 26 - 3	•	•	26	2.4	3.1	110	39	SDGN/R 3102		32.30.604	
DGIH 32 - 3	•	•	32	2.4	3.1	150	39				

SDG.

Stechdreheinsätze Grooving and Parting-off Inserts

System SDGN

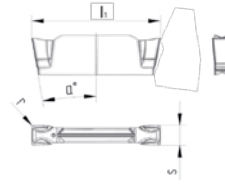

Drehen
Turning

Fräswerkzeuge
Milling Tools

HDS-/VHM- Fräser
HDS-/Solid Carbide
Endmills

Stech- und
Abstechwerkzeuge
Grooving and
Parting off Tools

Mini/ Micro
Schneidwerkzeuge
Mini/ Micro Tools

Gewinde-
werkzeuge
Threading Tools

Wendepplattenbohrer
VHM-Bohrer
Indexable Drills
Solid Carbide Drills

Bezeichnung Part Number	Lager Stock		Anwendung Application	S	l ₁	r	
	GM 5130 (M30/K20C)	GM 5125 (M25/K25C)		mm	mm	mm	
SDGN 2202 - F	●		Niro <i>Stainless Steel</i>	2.2	21.0	0.20	R/L 275.....02
SDGN 2202 - JM		●	Stahl / Niro <i>Steel / Stainless Steel</i>	3.1	20.0	0.20	R/L 275.....03 DGIH ... - 3
SDGN 2202 - M	○		Stahl <i>Steel</i>	3.1	20.0	0.20	
SDGN 3102 - F	●		Niro <i>Stainless Steel</i>	3.1	20.0	0.20	
SDGN 3102 - JM		●	Stahl / Niro <i>Steel / Stainless Steel</i>	3.1	20.0	0.20	R/L 275.....04
SDGN 3102 - M	●		Stahl <i>Steel</i>	3.1	20.0	0.20	
SDGN 4003 - M	●		Stahl <i>Steel</i>	4.1	18.9	0.20	R/L 275.....02
SDGR 2202 - JF-15		●	Stahl / Niro <i>Steel / Stainless Steel</i>	2.2	21.0	0.20	R/L 275.....03 DGIH ... - 3
SDGR 3102 - JF-15		●	Stahl / Niro <i>Steel / Stainless Steel</i>	3.1	18.9	0.20	

Drehen
Turning

Fräswerkzeuge
Milling Tools

HDS-/VHM-Fräser
HDS-/Solid Carbide
Endmills

Stech- und
Abstechwerkzeuge
Grooving and
Parting off Tools

Mini/ Micro
Schneidwerkzeuge
Mini/ Micro Tools

Gewinde-
werkzeuge
Threading Tools

Wendepplattenbohrer
VHM-Bohrer
Indexable Drills
Solid Carbide Drills

ISO	P						M				K					
	Schnittgeschwindigkeiten <i>Cutting Speeds</i>															
Material <i>Material</i>	hoch <i>high</i>		mittel <i>medium</i>		niedrig <i>low</i>	unterbrochener Schnitt <i>intermittent cutting</i>		hoch <i>high</i>	mittel <i>medium</i>		niedrig <i>low</i>	hoch <i>high</i>	mittel <i>medium</i>		niedrig <i>low</i>	
	P01	P10	P20	P30	P40	P50	M10	M20	M30	M40	K01	K10	K20	K30	K40	
Hartmetall beschichtet <i>Coated carbide</i>			GP 5125									GP 5125				
					GM 5125							GM 5130				
		GP 2120										GK 5320				
				GP 2235								GP 2120				
Hartmetall unbeschichtet <i>Uncoated carbide</i>												GK 1110				
												GK 1120				