

## Corcut 2.0

### VHM-Schaftfräser mit Eckenradius



JD 74102



Corcut 2.0 bis 55 HRC

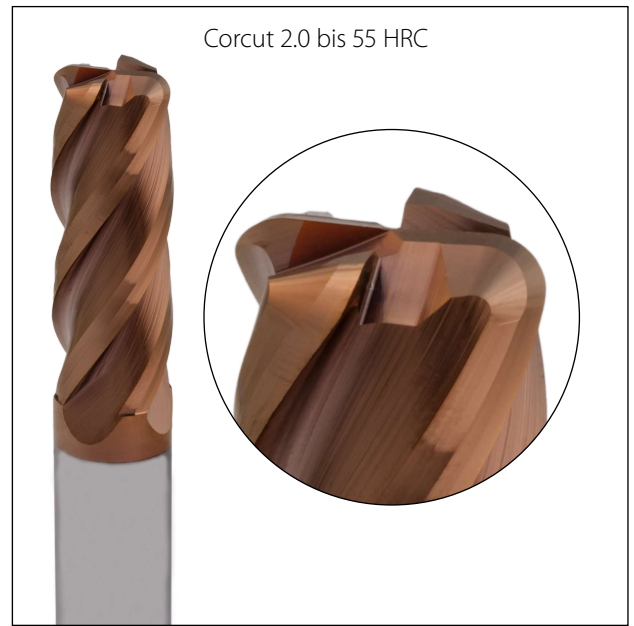

- Hohe Formgenauigkeit des Werkstücks durch höchste Konturgenauigkeit des Eckenradius
- Beste Standzeiten und Standwege durch den speziellen Radiusanschliff
- Für rostfreie Stähle, Baustähle und Guss
- Upgrade auf die hitzebeständige und extrem verschleißfeste TiSiN- Beschichtung
- Einfache Verschleißmarkenerkennung



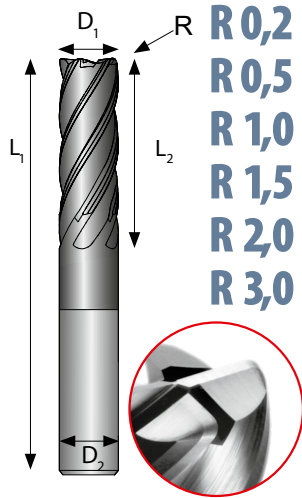

Bezeichnung Part Number	Bestellnummer Order number	Maße Dimensions [mm]						z Flutes	DN 8130 (TiSiN)
		D <sub>1</sub>	R	D <sub>2</sub> h <sub>6</sub>	L <sub>1</sub>	L <sub>2</sub>			
JD 74102 030 02 CR HA	10006932058	3	0.2	3	50	9	4	•	
JD 74102 030 05 CR HA	10006933058	3	0.5	3	50	8		•	
JD 74102 030 10 CR HA	10006934058	3	1.0	3	50	8		•	
JD 74102 040 02 CR HA	10006935058	4	0.2	4	50	10		•	
JD 74102 040 05 CR HA	10006936058	4	0.5	4	50	10		•	
JD 74102 040 10 CR HA	10006937058	4	1.0	4	50	10		•	
JD 74102 050 05 CR HA	10006938058	5	0.5	5	50	13		•	
JD 74102 050 10 CR HA	10006939058	5	1.0	5	50	13		•	
JD 74102 060 05 CR HA	10006940058	6	0.5	6	50	15		•	
JD 74102 060 10 CR HA	10006941058	6	1.0	6	50	15		•	
JD 74102 060 15 CR HA	10006942058	6	1.5	6	50	15		•	
JD 74102 060 20 CR HA	10006943058	6	2.0	6	50	15		•	
JD 74102 080 05 CR HA	10006944058	8	0.5	8	60	20		•	
JD 74102 080 10 CR HA	10006945058	8	1.0	8	60	20		•	
JD 74102 080 15 CR HA	10006946058	8	1.5	8	60	20		•	
JD 74102 080 20 CR HA	10006947058	8	2.0	8	60	20		•	
JD 74102 100 05 CR HA	10006948058	10	0.5	10	75	25		•	
JD 74102 100 10 CR HA	10006949058	10	1.0	10	75	25		•	
JD 74102 100 15 CR HA	10006950058	10	1.5	10	75	25		•	
JD 74102 100 20 CR HA	10006951058	10	2.0	10	75	25		•	
JD 74102 100 30 CR HA	10006952058	10	3.0	10	75	25		•	
JD 74102 120 05 CR HA	10006953058	12	0.5	12	75	30		•	
JD 74102 120 10 CR HA	10006954058	12	1.0	12	75	30		•	
JD 74102 120 15 CR HA	10006955058	12	1.5	12	75	30		•	
JD 74102 120 20 CR HA	10006956058	12	2.0	12	75	30		•	
JD 74102 120 30 CR HA	10006957058	12	3.0	12	75	30		•	
JD 74102 160 05 CR HA	10006958058	16	0.5	16	100	45		•	
JD 74102 160 10 CR HA	10006959058	16	1.0	16	100	45		•	
JD 74102 160 20 CR HA	10006960058	16	2.0	16	100	45	•		
JD 74102 160 30 CR HA	10006961058	16	3.0	16	100	45	•		

• JD-Lager / JD-Stock

○ auf Anfrage lieferbar / upon request



Technische Änderungen vorbehalten, keine Haftung für Druckfehler. Abbildungen ähnlich.  
Technical changes reserved, we bear no liability for misprints. Drawings/pictures similar.



**Jörn Detjens Zerspanungstechnik GmbH**  
Bookkoppel 3  
DE-22926 Ahrensburg

Tel.: +49-(0)41 07 - 90 73-0  
Fax.: +49-(0)41 07 - 90 73-22  
E-Mail: info@jd-tools.de

